



SCDP

Self Compensating Duct Probes

APPLICATION

- The Groveley Self Compensating Duct Probe (SCDP) has been designed to allow simple, trouble free, representative sampling of duct environments. When used in conjunction with a Groveley GD-A aspirator it provides a complete duct sampling system capable of operating in hazardous areas.
- The SCDP draws a representative sample from the whole width of a duct, no matter what the flow rate or pressure in the duct. The design ensures equal volumes of sample are drawn from each duct sampling point, before combining them prior to introduction to an aspirator.
- The SCDP operates on the “reverse wing” principle (see diagram 1). The contour of the SCDP creates an area of negative pressure on the opposite side to the airflow direction. The samples are drawn from this area behind the probe protecting the sample holes from becoming blocked by particulate in the duct.
- Large particles carried by the flow in the duct, which may block sampling points of traditional probes, will either be too heavy to be drawn into the negative pressure area, or will impact on the face of the SCDP. In either case the SCDP sampling holes will remain unaffected.

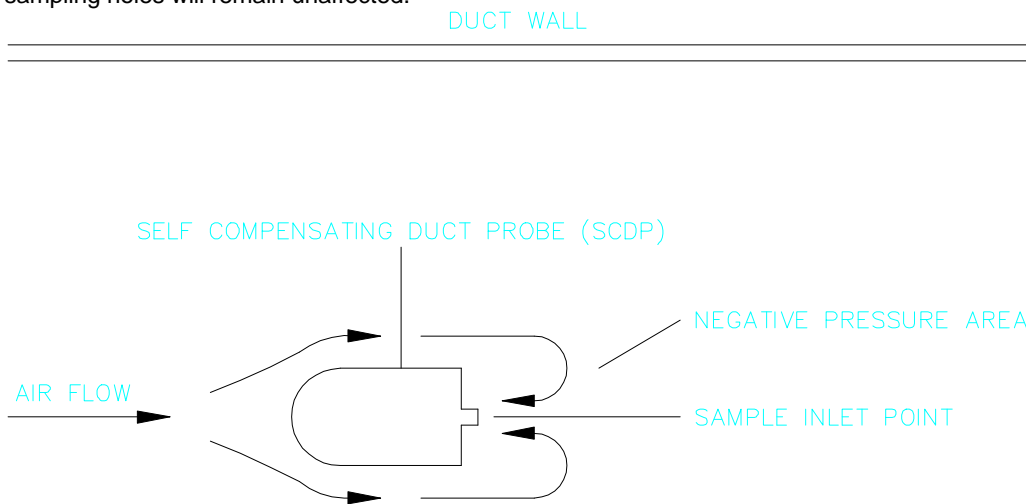

CROSS SECTIONAL VIEW OF SCDP IN DUCT

TECHNICAL DATA

Construction - All external surfaces are 316 stainless steel. Internal components are either PTFE or delryn which are resistant to attack by corrosive gases, Hydrogen Sulphide for example.

If required neoprene sealing gaskets and delryn isolation sleeves can be provided to isolate the SCDP from the duct wall.

Dimensions - Each SCDP is manufactured to fit exactly into a customers duct. Maximum length 4m.

For details of the mounting arrangement see below.

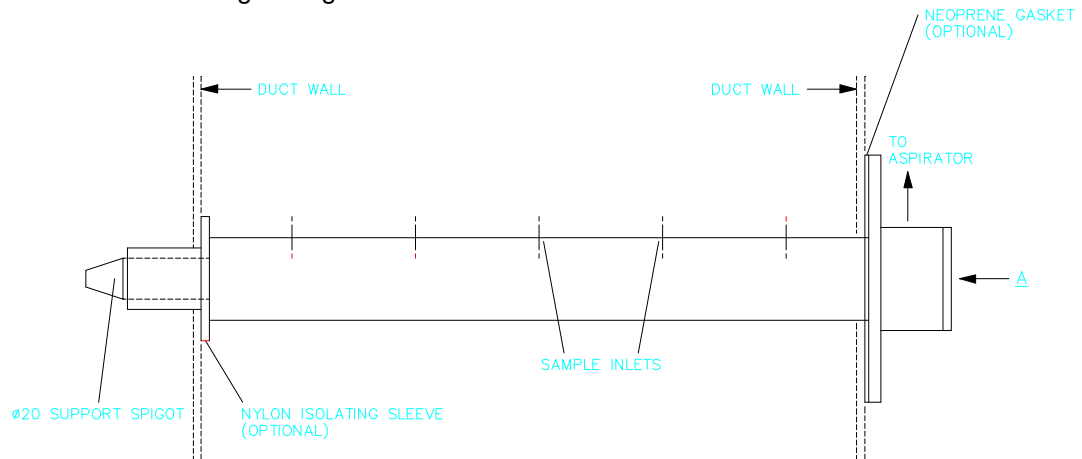
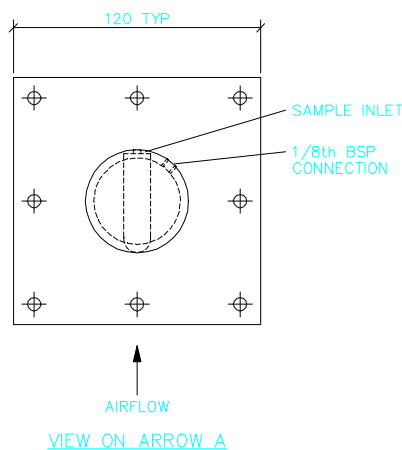

DIAGRAM SHOWING SCDP MOUNTED IN A DUCT



Contact

Benelux
Sense-Ware v.o.f.
Bovenbuurtweg 78
NL-6717 XB Ede, The Netherlands
Tel.: +31 (0) 318 575 237
Fax: +31 (0) 318 575 682
E-mail: sales@Sense-Ware.com
Web: www.Sense-Ware.com

UK (Factory)
Groveley Detection Limited
Anchor Works, Groveley Road
Christchurch, Dorset BH23 3HB
Tel.: +44 (0) 1202 483497
Fax: +44 (0) 1202 486658
E-mail: sales@Groveley.co.uk
Web: www.Groveley.co.uk

Due to the policy of continued product development exercised by Groveley Detection Limited the company reserves the right to alter or amend information in their publications without prior notice and no responsibility can be accepted for errors or omissions.

